

SCREW TO CONNECT COUPLINGS

HSC 5000 SERIES

SCREW COUPLINGS FOR HIGH PRESSURE PULSE APPLICATIONS.

CONNECT & DISCONNECT UNDER PRESSURE

INTRODUCTION

Holmbury HSC 5000 Series of heavy duty, high-pressure, screw couplings are designed to withstand the most severe pressure pulse applications, where other couplings suffer rapid failure.

APPLICATIONS

Excavator hammer attachments, shears, rock crushers, test rigs and other intense pressure pulse application.

ADVANTAGES

- ★ Screw thread connection eliminates Brinelling
- ★ Connects and disconnects under pressure
- ★ Seals readily accessible for easy replacement
- ★ Supplied with Caps and Plugs to protect the thread and help prevent the ingress of contaminants
- ★ When connected, all internal parts are held rigid, preventing fatigue of the poppet, spring or coupling itself. The poppet is guided to prevent it shifting off centre. The poppet and spring are retained by a heavy duty collet that can withstand severe forces.

ORDER CODES

HSC 5000 – 19 – M – 12 G V	
Type HSC 5000	V = Viton seals
Body Size 10 = 3/8" 12 = 1/2" 19 = 3/4" 25 = 1" 32 = 1 1/4" 40 = 1 1/2" 50 = 2"	Blank = Female thread M = Male thread
M = Male Coupling F = Female Coupling	Thread form G = BSP P
	Thread size based on dash system 06 = 3/8" 08 = 1/2" 12 = 3/4" 16 = 1" 20 = 1 1/4" 24 = 1 1/2" 32 = 2"

Example: HSC 5000-19-M-12G V

HSC 5000, 3/4" body size, male coupling, 3/4" thread, BSP P thread form, female thread, viton seals.



PRESSURE DROP CHARACTERISTICS

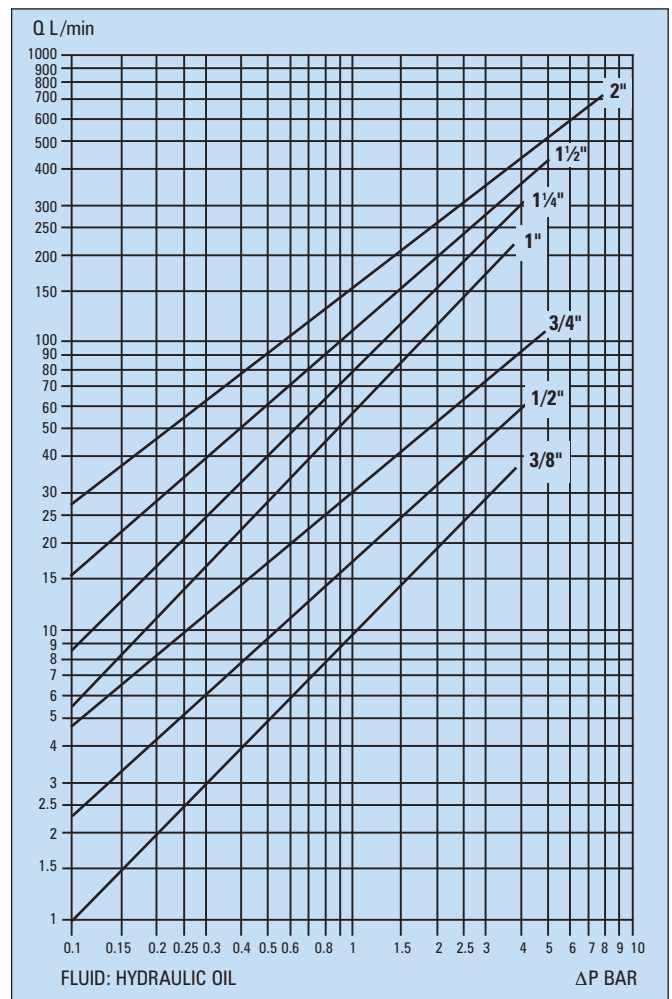

MATERIALS

Zinc plated carbon steel body with Viton seals and PTFE backing rings.

HSC 5000 SERIES, SCREW COUPLINGS

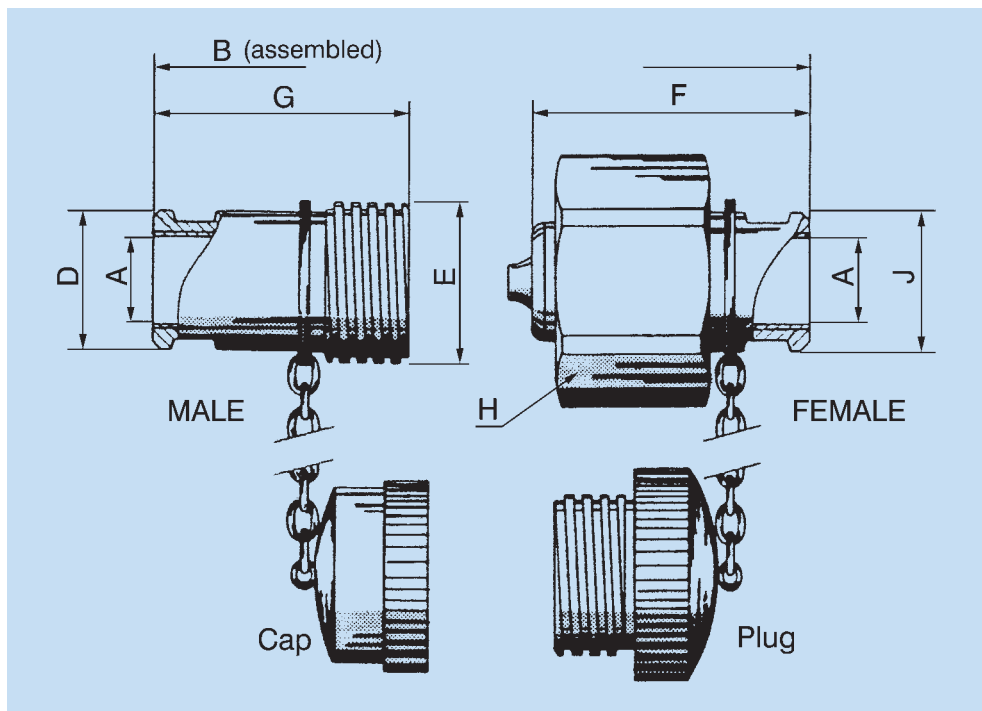

TECHNICAL DATA

Size	A	B	D	ØE	F	G	H	J	Weight Female kg	Weight Male kg	Flow area mm ²	Max Flow litres/min	Max Working pressure bar
HSC 5000 10	3/8"	110	30	35.57	55	77	45	27	0.37	0.35	45	26	500
HSC 5000 12	1/2"	135	35	39.64	70	95	50	30	0.53	0.53	95	52	450
HSC 5000 19	3/4"	142	40	44.80	73	99	55	35	0.67	0.72	150	85	400
HSC 5000 25	1"	156	46	57.52	82	106	70	52	1.23	1.25	250	150	350
HSC 5000 32	1 1/4"	171	60	65.55	88	118	80	55	1.92	1.70	370	230	320
HSC 5000 40	1 1/2"	172	68	74.61	90	121	87	62	2.26	2.20	500	340	300
HSC 5000 50	2"	240	90	108.05	120	165	130	85	7.30	6.30	980	630	250

Dimensions in mm except where stated otherwise.

Do not exceed maximum flow rating as this will invalidate the warranty and may cause seal damage.

ACCESSORIES



WRENCH

To prevent the locking nut on the female half from loosening under severe vibrating conditions, it is essential that it's lightly tightened. The special short handle wrench shown here is ideal for this purpose.

WELDABLE BRACKET

The bracket is welded into position on the equipment and the coupling slotted into the jaws of the bracket. Both the male and female halves have machined flats (as can be seen in the photograph above) for this purpose. The coupling is retained in the bracket with the clamping nut and bolt.