

IAPC SERIES

1/2" ISO.A "Connect-under-pressure"

PULL BREAK AND PUSH PULL HYDRAULIC COUPLINGS

INTRODUCTION

Holmbury IACP Series ISO.A couplings incorporate pressure relief mechanisms that enable them to be connected by hand, even when there are residual pressures in the hose lines.

When male and female IACP couplings are used, they can be connected when there is residual pressures of up to 250 bar in either of the hose lines.

If an IACP coupling is to be connected with a standard ISO.A coupling, then the hose with the IACP coupling can have up to 250 bar residual pressure whilst the hose with the standard coupling must be at zero pressure.

PULL BREAK FEMALE COUPLINGS

Used for connecting flexible hose lines. To connect, pull back the locking sleeve, insert the male, release the sleeve. To disconnect, pull back the locking sleeve and withdraw the male.

PUSH PULL FEMALE COUPLINGS

The coupling is panel mounted using the circlip grooves in the locking sleeve. The male is connected by being pushed in and disconnected by being pulled out. This release mechanism protects the coupling and hose from damage in the event of an accidental separating force being applied to the connection (e.g. a trailer becoming detached from the towing vehicle).

TECHNICAL DETAILS

Maximum working pressure 250 bar.

Fluid loss connecting with residual pressure 1.5 ml.

Connection force without residual pressure 90 N.

Connection force with residual pressure from:

$$CF = 90 + (0.55 \times RP)$$

CF = connection force (N)

RP = residual pressure (bar)

EXAMPLE

To connect a PC coupling with 220 bar residual pressure, $CF = 90 + (0.55 \times 220) = 211$ N

ORDER CODES

IACP 12 - M - 08 G	
ISO A connect under pressure	Any other necessary information
Coupling size 12 = 1/2"	Blank = Nitrile seals
M = Pull break male F = Pull break female P = Push Pull female	Blank = Female thread M = Male thread
Thread size based on dash system 08 = 1/2"	Thread form G = BSP P



PRESSURE DROP CHARACTERISTICS

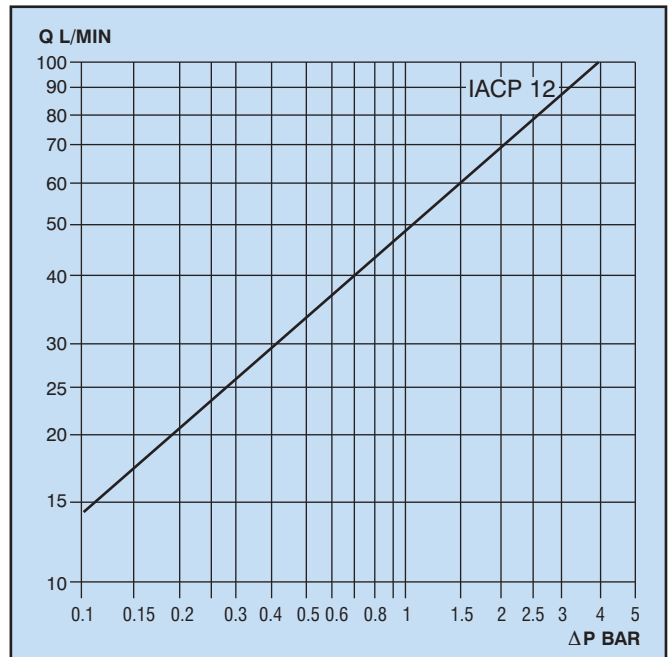

MATERIALS

Zinc plated carbon steel body with nitrile seals and PTFE backing ring.

**IACP SERIES, 1/2" ISO.A "Connect-under-pressure"
PULL BREAK AND PUSH PULL HYDRAULIC COUPLINGS**

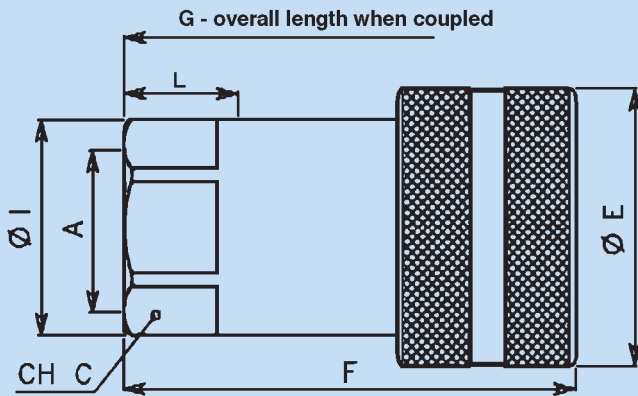

IACP SERIES PULL BREAK FEMALE COUPLING

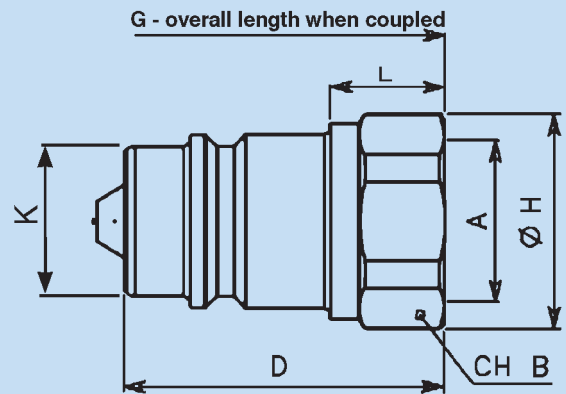

IACP SERIES MALE COUPLING

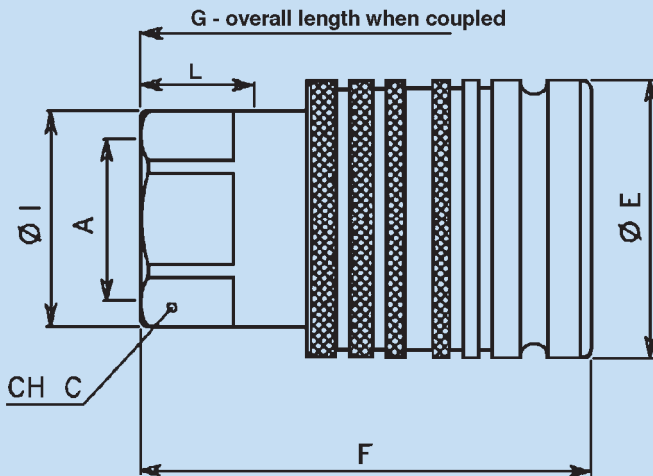

IACP SERIES PUSH PULL FEMALE COUPLING

ACCESSORIES



Plastic caps and plugs for males and Pull Break females
Page 77



Flip top plastic caps for Push Pull females
Page 76



Parking stations for males
Page 78

For further details see the Holmbury catalogue or web site

MALE COUPLING DIMENSIONS

Type	Thread	A	B	D	G	H	K	L*	Weight (kg)
IACP12-M-08G	1/2"	1/2"	27	44.5	85.7	29	20.5	16	0.085

* L = Thread depth

PULL BREAK FEMALE DIMENSIONS

Type	Thread	A	C	E	F	G	I	K	L*	Weight (kg)
IACP12-F-08G	1/2"	1/2"	27	38	63.3	85.7	30	20.5	16	0.245

* L = Thread depth

PUSH PULL FEMALE DIMENSIONS

Type	Thread	A	C	E	F	G	I	K	L*	Weight (kg)
IACP12-P-08G	1/2"	1/2"	27	38	63.3	85.7	30	20.5	16	0.245

* L = Thread depth