

MISCELLANEOUS COUPLINGS

SP SERIES

HIGH PRESSURE, POPPET TYPE, SCREW COUPLINGS

INTRODUCTION

Holmbury High Pressure Poppet Type Screwed Couplings are designed to withstand high pressures and pressure pulses. High pressure pulses create forces that act to separate the male and female couplings. With couplings that use ball-in-groove retaining mechanisms, the separating forces are concentrated onto a relatively small area - point contact of the balls - which can cause Brinelling (indentation of the balls into the groove). Brinelling will lead to leakage and eventually seizure of the coupling. Screwed couplings have a screw thread retaining mechanism that distributes the separating forces over a large surface area, thus eliminating brinelling.

FEATURES

- ★ Screw thread retaining mechanism to eliminate brinelling
- ★ Connection and disconnection can be performed even with a low residual hydraulic pressure in the line

APPLICATIONS

Mobile plant, agricultural implements and general industrial equipment.

MATERIALS

Zinc plated carbon steel body material with nitrile seals and PTFE backing ring.

TECHNICAL DETAILS

Working temperature range with nitrile seals is -20°C to +100°C

Couplings are also available with Viton seals for an operating temperature range of -15°C to +180°C.

MAXIMUM WORKING PRESSURE (BAR)

Size	06	10	12	19	25	32	40	50
Male	950	750	750	650	450	450	300	300
Female	950	750	750	650	450	450	300	300

**DUST CAPS
SEE PAGE 76**



PRESSURE DROP CHARACTERISTICS

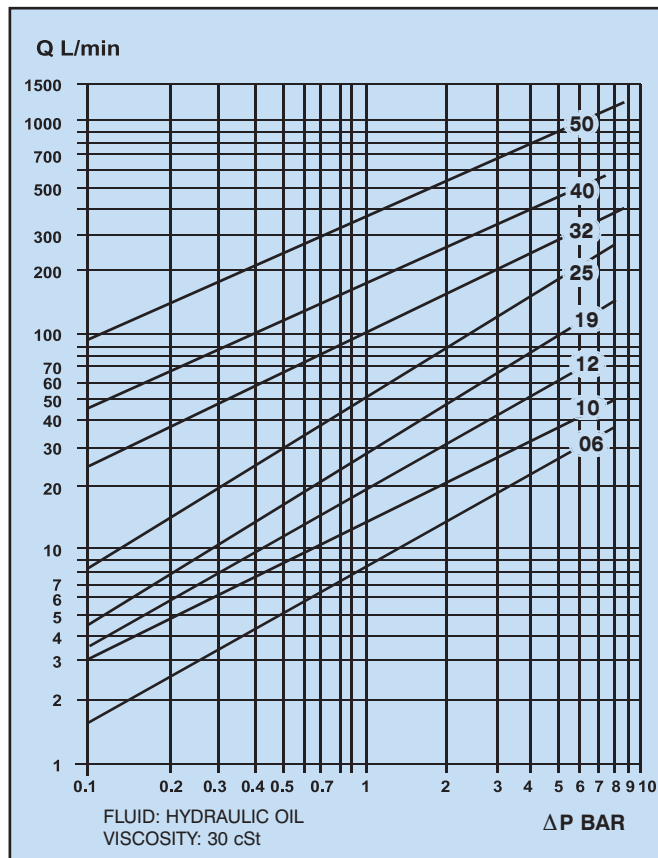

SP SERIES, HIGH PRESSURE, POPPET TYPE, SCREW COUPLINGS

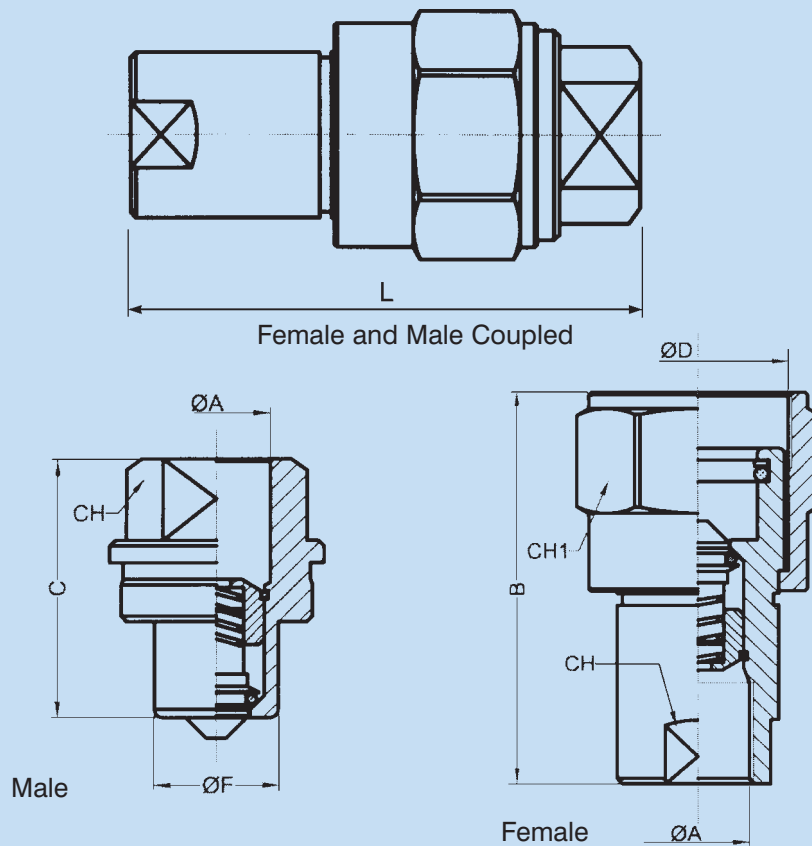

Size	ØA	B	C	CH	CH1	ØD	ØF	L
SP 06	1/4" BSP	57	34	19	32	27 x 1.5	14.9	68
SP 10	3/8" BSP	71.5	41	22	34	30 x 1.5	18.9	86
SP 12	1/2" BSP	74.5	47	27	41	35 x 1.5	22	94
SP 19	3/4" BSP	90.5	57	35	50	45 x 1.5	29	114
SP 25	1" BSP	103.5	64	41	65	54 x 1.5	36	128
SP 32	1¼" BSP	130.5	75	58	80	70 x 2.0	49.8	150
SP 40	1½" BSP	141	81	61	85	78 x 2.0	55	162
SP 50	2" BSP	205	129	71	105	92 x 3.0	69	236

ORDER CODES

SP 50 - M - 32 G	
SP Series	
Coupling Size	
M = Male coupling F = Female coupling	
Thread size (dash system)	Any other information
04 = 1/4" 16 = 1"	Blank = Nitrile Seals
06 = 3/8" 20 = 1¼"	
08 = 1/2" 24 = 1½"	
12 = 3/4" 32 = 2"	F = Female thread
Thread Form	M = Male thread
G = BSP P	If blank then female thread is supplied.
N = NPT F	

Example: SP50-M-32G

SP Series, size 50 male coupling, 2" BSP female thread, nitrile seals, no special requirements.