

MISCELLANEOUS COUPLINGS

TC SERIES

TIPPER COUPLINGS

INTRODUCTION

Holmbury Tipper Couplings use a screw thread connection. The female coupling has a wing nut sleeve which enables operators to connect the couplings by hand, even when there is low residual pressure in the line.

APPLICATIONS

Tipper Couplings are designed for use on mobile plant such as commercial vehicle trailers, agricultural equipment and construction plant.

MATERIALS

Zinc plated carbon steel body material with nitrile seals and PTFE backing ring.

TECHNICAL DETAILS

Maximum working pressure for both sizes is 250 bar. Working temperature range with nitrile seals is -20°C to +100°C

ACCESSORIES

PARKING STATIONS

Parking stations help avoid accidental damage and provide a storage location.

PLUGS

Available for female couplings to prevent the ingress of dirt and avoid damage.

CAPS

Available for male couplings to prevent the ingress of dirt and avoid damage.



PRESSURE DROP CHARACTERISTICS

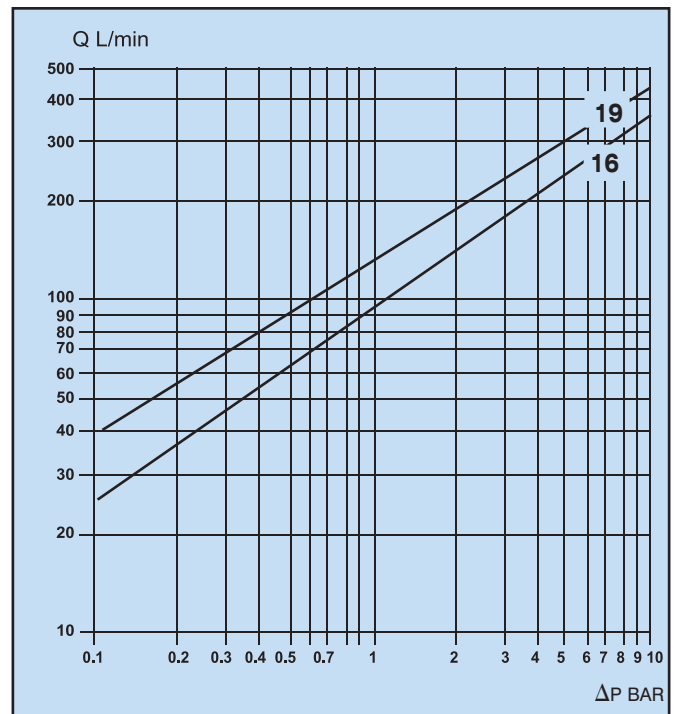

ORDER CODES

	TC	16 - F - 12	G	
TC Series				
Coupling Size				
M = Male coupling				Any other information
F = Female coupling				
Thread size (dash system)				Blank = Nitrile Seals
12 = 3/4"				
16 = 1"				
Thread Form				F = Female thread
G = BSP P				M = Male thread
				If blank then female thread is supplied.

DUST CAPS - PAGE 77
PARKING STATIONS - PAGE 78



Example: TC16-F-12G

TC Series tipper coupling, size 16 female coupling, 3/4" BSP female thread, nitrile seals, no special requirements.

TC SERIES, TIPPER COUPLINGS

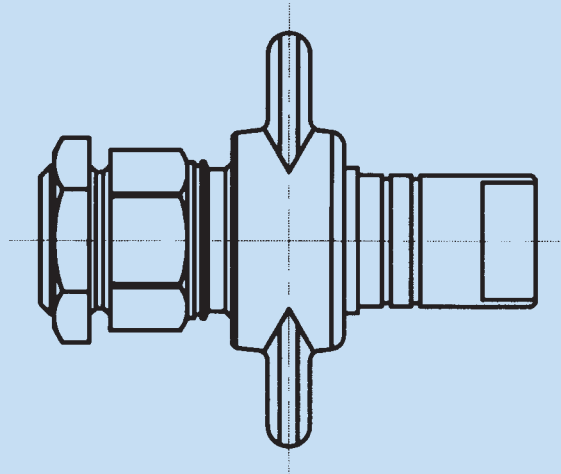

Female and Male Coupled

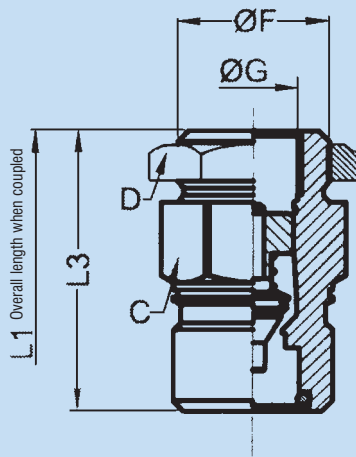

Male

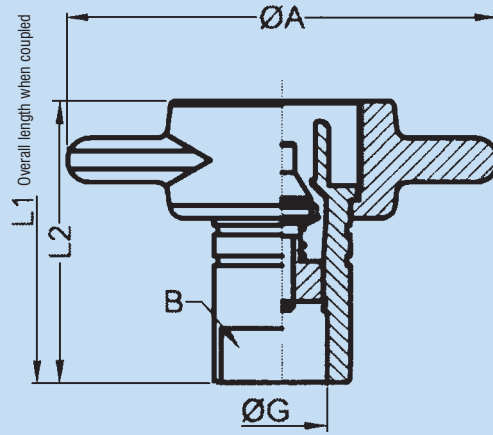

Female

Male coupling

Size	ØG	C	D	L1	L3	ØF
TC 16 M 12	3/4" BSP	46	50	128.2	75.7	1 1/4"
TC 19 M 16	1" BSP	55	60	144.6	82.8	1 3/8"

Female coupling

Size	ØG	B	L1	L2	ØA
TC 16 F 12	3/4" BSP	33	128.2	74.5	115
TC 19 F 16	1" BSP	40	144.6	82.8	115