

ISO.A SERIES

PULL BREAK HYDRAULIC COUPLINGS

1/4" - 2" Poppet Valve Types to ISO 7241 Series A

INTRODUCTION

Holmbury ISO.A Series couplings are the ideal choice where a tough, durable product of superior quality is required. They are perfectly suited to industrial and agricultural applications. A poppet valve is used to minimise the pressure drop characteristics and provide a positive sealing arrangement.

COMPARISONS

In comparison to ISO.B couplings the ISO.A Series are:

1. Smaller.
2. Easier to connect and release.

FEATURES

- ★ Positive, quick connection ensured by the snap together locking ball system.
- ★ When connected the male and female halves can rotate, even under pressure, thus avoiding any torsional stress in the flexible hoses.
- ★ Designed to withstand high pressure peaks and pulses.
- ★ Poppet valves have balanced springs and calibrated oil flow passages to minimise the pressure drop.
- ★ Poppet valve seals have shockproof protective edges.

MATERIALS

Zinc plated, heat treated carbon steel. Nitrile 'O' ring seals are fitted as standard. VITON seals are available on request.



ISO.A SERIES COUPLINGS
FLOW GRAPH

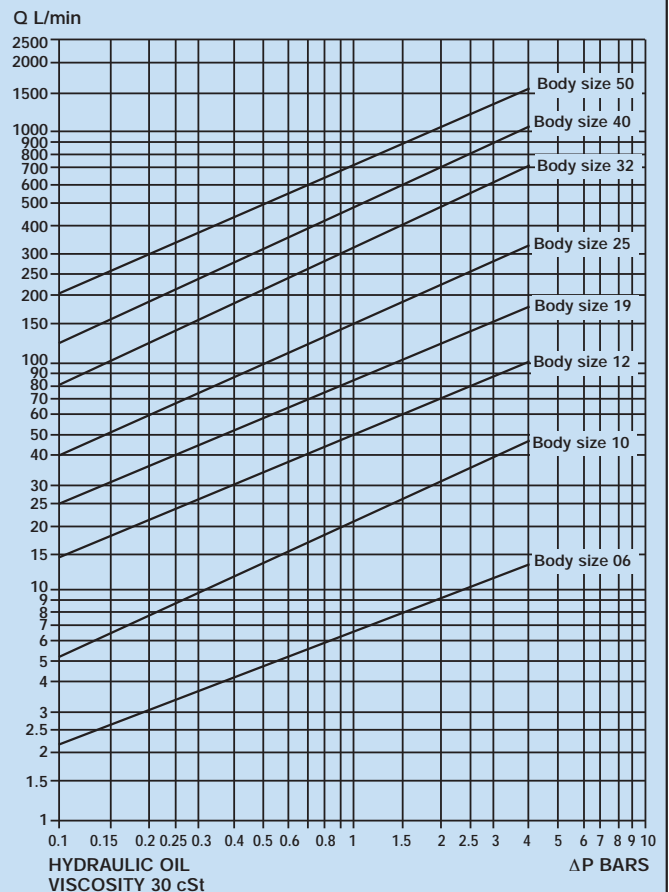

PARKING STATIONS - SEE PAGE 76
DUST CAPS - SEE PAGE 75



ISO.A SERIES PULL BREAK HYDRAULIC COUPLINGS

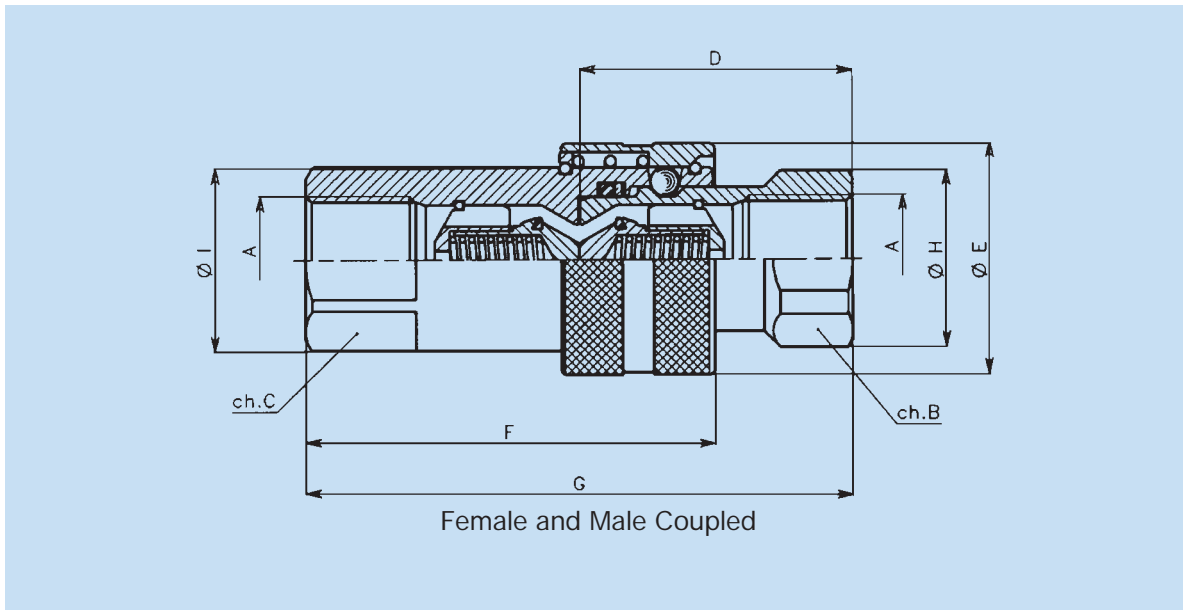

Body Size	Nominal Diameter	Maximum Working Pressure (bar)	A*	B	C	D	E	F	G	H	I	Weight (kg)
IA06	6.3	350	1/4"	19	19	32	26	47	64.5	21	22	0.13
IA10	10	300	3/8"	22	22	38	31	56	76.5	24	24	0.20
IA12	12.5	250	1/2"	27	27	44.5	38	63	86	29	30	0.34
IA19	20	250	3/4"	36	38	55	48	82	111	38.5	44	0.71
IA25	25	230	1"	41	45	63	54	97	127	45	52	1.10
IA32	31.5	230	1 1/4"	55	50	75	65	117	151	60	56	1.90
IA40	40	190	1 1/2"	60	60	85	80	135	171	65.5	65.5	3.10
IA50	50	130	2"	75	75	100	100	160	201	82.5	83.5	5.50

A* = inch size BSP or NPT. Other dimensions in mm.

ORDER CODES

IA	19	- M	- 12	G	
IA = ISO A Series					Blank = Nitrile seals
Body Size 06 = 1/4" 10 = 3/8" 12 = 1/2" 19 = 3/4" 25 = 1" 32 = 1 1/4" 40 = 1 1/2" 50 = 2"					Blank = Female thread M = Male thread
					Thread form G = BSP P (standard) N = NPT (available on request) S = SAE (available on request)
M = Male Coupling F = Female Coupling					Thread size based on dash system 04 = 1/4" 16 = 1" 06 = 3/8" 20 = 1 1/4" 08 = 1/2" 24 = 1 1/2" 12 = 3/4" 32 = 2"

Example: IA19-M-12 G
ISO A, 3/4" body size, male coupling, 3/4" thread, BSP P thread form, female thread, nitrile seals.