

TB SERIES TRAILER BRAKE COUPLINGS

INTRODUCTION

Holmbury Trailer Brake Couplings are used to connect the hydraulic braking system of tractors to their trailers. The male coupling is normally panel mounted on the tractor and is available with metric and BSP threads.

APPLICATIONS

Agricultural tractors and trailers.

MATERIALS

Zinc plated carbon steel body material with nitrile seals and PTFE backing ring.

TECHNICAL DETAILS

Maximum working pressure for all sizes of couplings is 220 bar. Working temperature range with nitrile seals is -20°C to +100°C

PARKING STATIONS

To help avoid accidental damage and provide a storage location, Parking Stations are supplied as standard with each female coupling

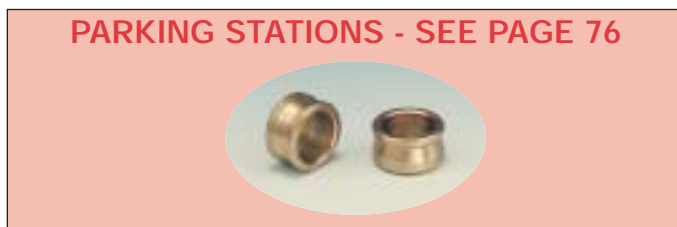

ORDER CODES

TB 12 - M - 08 G M

<p>TB = Trailer Brake</p> <hr/> <p>Body size 12 = 1/2"</p> <hr/> <p>M = Male coupling F = Female coupling</p> <hr/> <p>Thread size (dash system) - 06 = 3/8" - 08 = 1/2"</p> <hr/> <p>Thread size (metric) 18 = 18 mm 20 = 20 mm</p>	<p>Any other information</p> <hr/> <p>F = Female thread M = Male thread If blank then female thread is supplied.</p> <hr/> <p>G = BSP P M = Metric</p>
---	--

PRESSURE DROP CHARACTERISTICS

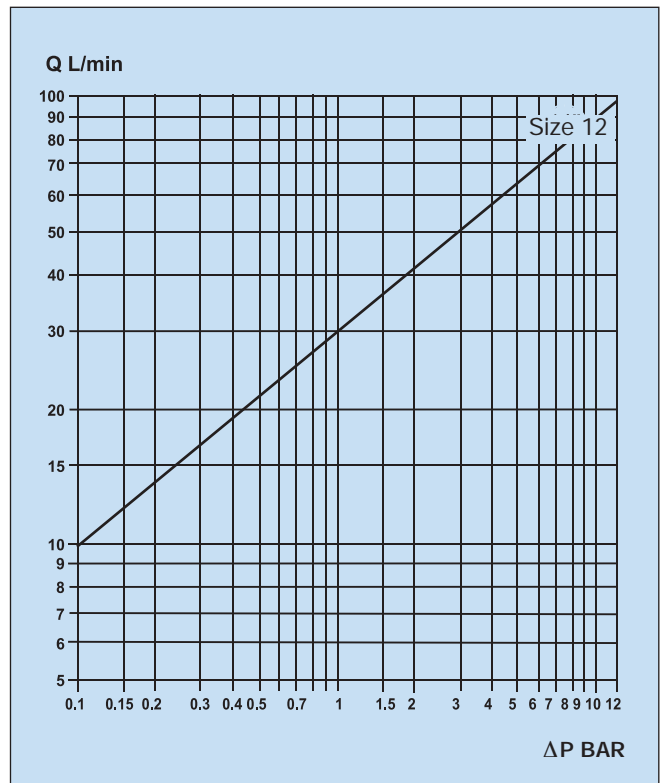

TB SERIES, TRAILER BRAKE COUPLINGS

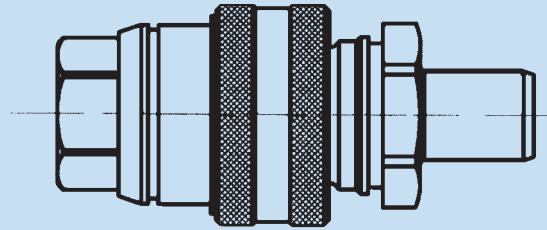

Female and Male Coupled

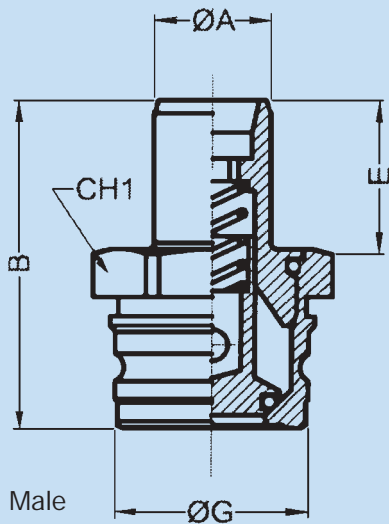

Male

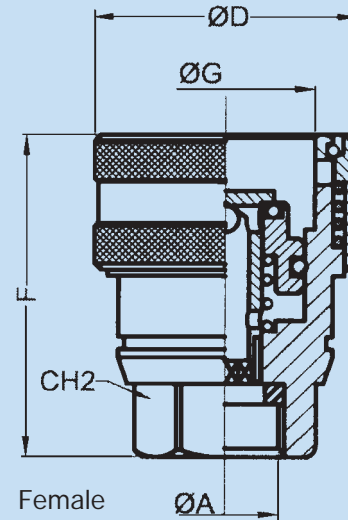

Female

Male

Order Code	ØA	B	CH1	ØG	E
TB12-M-18MF	18 x 1.5	51	32	29.8	23
TB12-M-20MF	20 x 1.5	51	32	29.8	23
TB12-M-08F	1/2" BSP	43	32	29.8	15
TB12-M-08FF	1/2" BSP F	59	32	29.8	31

Other threads available on request. Locknuts are not included

Female

Order Code	ØA	B	CH1	ØD	F
TB12-F-18MF	18 x 1.5	30	27	45	55
TB12-F-20MF	20 x 1.5	30	27	45	55
TB12-F-08F	1/2" BSP	30	27	45	55
TB12-F-06F	3/8" BSP	30	27	45	55

Other threads available on request. Locknuts are not included